

TCP Monitoring, Correction and Measurement "out-of-the-box"

VMT ToolBox 3D

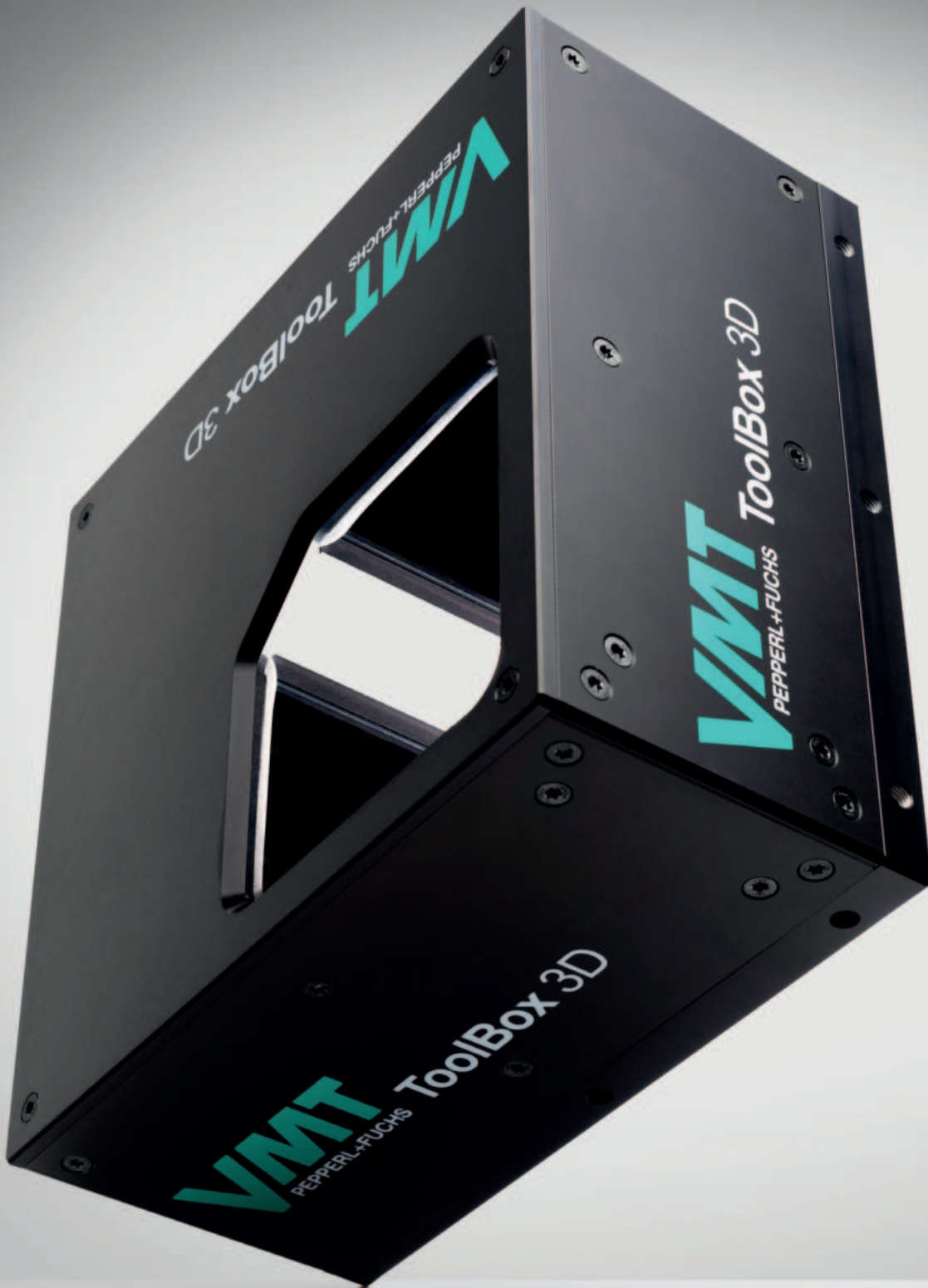



VIMT
PEPPERL+FUCHS
ToolBox 3D

VIMT
PEPPERL+FUCHS
ToolBox 3D

VIMT
PEPPERL+FUCHS
ToolBox 3D

VIMT
PEPPERL+FUCHS
ToolBox 3D

VMT ToolBox 3D – Your Competitive Advantage

Continuous and precise monitoring of robot tools ensures application quality and, in turn, product quality. As an element that interacts directly with the product, the robot end effector is often impacted by contamination and mechanical stress.

Only fully automated monitoring of the TCP (tool center point) can prevent damage and application errors. ToolBox 3D is an integrated vision system that offers a reliable solution for fully automated TCP monitoring in industrial applications.

Contamination or geometric irregularities can be detected in the process and, in most cases, even corrected without affecting cycle times. This ensures optimal application availability, even in the event of an error.

Combined with the VMT BK path correction system, which enables precise adjustment of robot paths based on changes in component shape and position, ToolBox 3D provides an even more powerful solution for ensuring application quality in robot-supported production processes.

ToolBox 3D stands for uncompromising, continuous inline quality monitoring of the robot TCP—which ensures overall quality of the application. The VMT ToolBox 3D can be flexibly integrated into nearly any environment, from complex control cabinet solutions to lean embedded systems.

Highlights

- Continuous TCP monitoring and correction
- Design data-free TCP determination
- Flexible Integration into existing systems
- Can be expanded for special tasks, from contamination detection to type verification
- Proven, rugged industrial solution

TCP Monitoring and Robot Tool Measurement "out-of-the-box"

To ensure consistently high application quality in robot-supported production processes, it is essential to regularly check the tool center point (TCP). Even minimal deviations of the TCP from its target position directly affect application quality.

ToolBox 3D is a fast, reliable solution developed by VMT for automated TCP monitoring and correction. Packaged in a compact, rugged industrial housing, the system consists of a high-resolution camera with special optics and integrated lighting.

To check and/or correct the TCP, the robot moves its tool into the ToolBox 3D inspection opening. Using a mirror system, the high-resolution camera generates images of the robot tool from various angles to build a multidimensional image. The position of the TCP can then be determined without reorientation of the tool—this not only saves time but also enables optimal use of the robot's limited workspace, especially with large tools.

In addition to checking and correcting the TCP, ToolBox 3D also enables high-precision determination of the TCP in all six degrees of freedom.

The robot tool is moved to different positions within the ToolBox 3D inspection opening, and a multidimensional image is captured in each position. The TCP can then be determined in robot coordinates, allowing new robot tools to be quickly and easily integrated into the system.

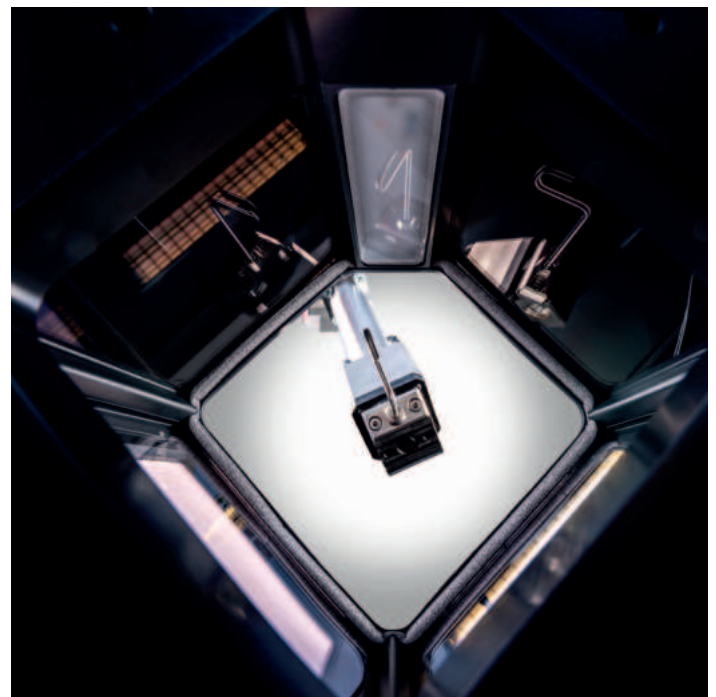

Features and and Technical Data

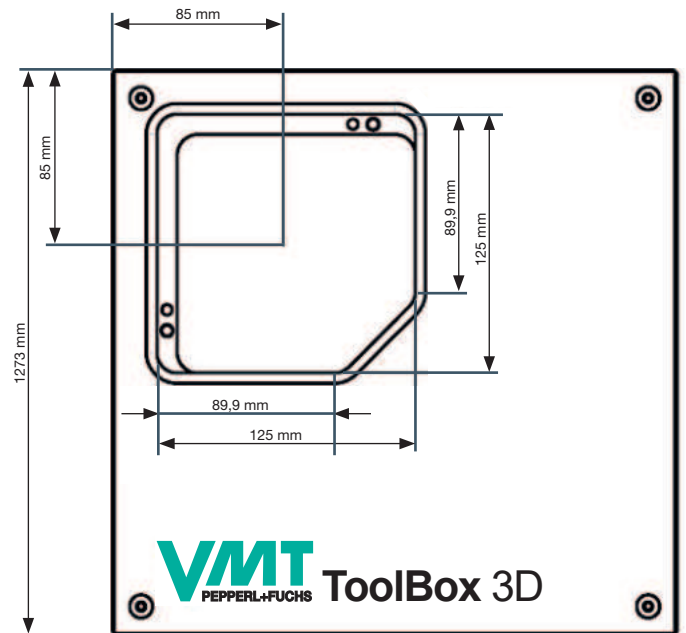
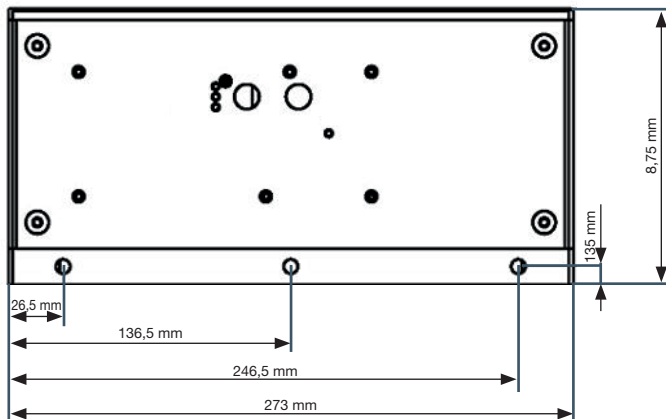

Features

- Quick check for deviation of the robot TCP from a pre-set reference
- Innovative mirror system saves time and space — the robot only has to move to one position for the check
- Transmission of correction data when determining a TCP deviation
- The tool can be corrected immediately and automatically in case of minor deviations
- High-precision TCP determination for new tools
- Simple, time-saving commissioning of additional tools — even without design data
- Compact design for space-saving integration into the application cell
- Also available as an embedded system — VMT ToolBox 3D+
- Not influenced by ambient light
- If the ToolBox 3D is accidentally moved, the coordinate origin can be restored without manual intervention — prevents downtime if there is a crash
- Glazed inspection area and open base protect against contamination

Technical Data ToolBox 3D

General data	Dimensions	273 x 273 x 110 mm (L x B x H)
	Dimensions Inspection bay	125 x 125 mm (L x B)
	Light type	White light (LED)
Electric data	Operating voltage	U_B 24 V DC \pm 20 % Power supply PoE
Interface	Interface type	TCP/IP
	Measurement duration	\leq 1,5 sec
Ambient conditions	Ambient temperature	0 ... 45 °C (32 ... 113 °F)
	Storage temperature	-20 ... 60 °C (-4 ... 140 °F)
Mechanical data	Degree of protection	IP40
	Mass	8700 g

Solution Excellence for Your Vision

VMT Vision Machine Technic Bildverarbeitungssysteme GmbH is your leading automation partner for machine vision turnkey solutions worldwide. VMT® develops and supplies customized machine vision, robot vision, and laser sensor systems for all industrial sectors using our self-developed state-of-the-art hardware and software products. As a professional consultant, VMT® provides objective solutions tailored to individual applications. Our technical services cover the complete life cycle of your machine vision solution, including planning, commissioning, installation, and system integration as well as training, maintenance, and upgrade services. With more than 25 years of experience in industrial machine vision applications, you can be confident that VMT® will provide proven solutions for your operation that nobody else can match.